

UAPC-1900 Keypad Scanner

Features

- ◆ Supports keypad size up to 8x8
- ◆ Internal de-bounce mechanism.
- ◆ Programmable scan cycle period
- ◆ Programmable de-bounce period
- ◆ Support single key press or multiple key presses
- ◆ Configurable key event detection: key-press, key-release, key-hold
- ◆ Individual key configurability

Overview

This is a highly flexible matrix keypad scanner for any applications that requires a simple user input interface. It includes an internal de-bounce mechanism to avoid contact bounce

noise.

Block Diagram

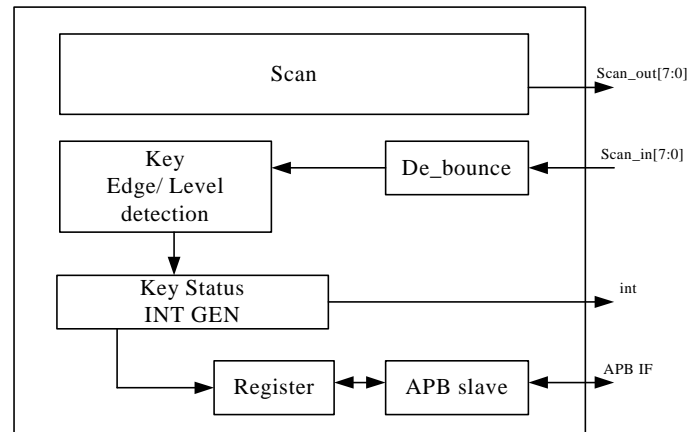

Global Unichip Corp.

TEL: +886-3-5646600

<http://www.globalunichip.com>

FAX: +886-3-5646000

e-mail: info@globalunichip.com

No. 10, Li-Hsin 6th Rd., Hsinchu Science Park, Hsinchu City 300, Taiwan

Description

This keypad scanner is intended to operate on AMBA APB bus and operates on APB bus clock. Eight column scan out pins and eight row scan in pins interfaces with common keypad pin configuration and supports keypad size up to 8x8. This scanner provides flexible configuration over: scan period, de-bounce period, scan signal polarity, key event detection, and interrupt generation.

The keypad scanner provides programmable scan cycle period and de-bounce period. Keys on the keypad can be configured individually to detect key-press, key-release, or key-hold events. Unused keys can be masked out. Scan out signals polarity and level/edge –triggered interrupt are also user programmable.

Deliverables

- Synthesizable RTL code in Verilog HDL
- Testbench and simulation environment
- DEMO system in FPGA
- User's manual

Global Unichip Corp.

TEL: +886-3-5646600 <http://www.globalunichip.com>

FAX: +886-3-5646000 e-mail: info@globalunichip.com

No. 10, Li-Hsin 6th Rd., Hsinchu Science Park, Hsinchu City 300, Taiwan