

## UPOR-1803-180

### 0. 18mm 1.8V Power On Reset Circuit (Type III)

#### Features

- ◆ Power supply transient immunity
- ◆ Resetable via external control
- ◆ CMOS and Open-drain outputs
- ◆ Single supply +1.8V operation
- ◆ Low quiescent current (1uA typ.)

#### Applications

- ◆ Reset of any digital circuitry after power on

#### Overview

The UPOR-1803-180 is a low-power 1.8V power-on reset (POR) circuit for digital circuits. It asserts a reset signal whenever the power supply voltage falls below the specified low-threshold and remains asserted for the minimum reset timeout period after power supply rises above the specified high-threshold.

The UPOR-1803-180 also features an additional reset input, RES, which provides another way to reset the digital circuits via external control. An open drain output is also available for high-voltage level (3.3V) conversion.

#### Block Diagram

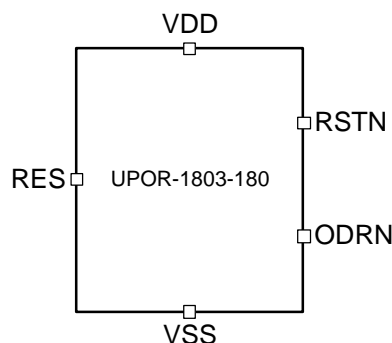

#### Description

The UPOR-1803-180 is a low power 1.8V power-on reset (POR) circuit that monitor the power supply voltage of digital circuit and issue an appropriate reset signal. It features a simple voltage detector with built-in delay and requires no external components.

The UPOR-1803-180 is implemented in TSMC 0.18 $\mu$ m logic salicide 1P6M 2.5V/3.3V CMOS process with 1P3M layout. The package of test chip is available in a 64-lead LQFP package. The evaluation board is available with the test chip.

#### *Global Unichip Corp.*

TEL: +886-3-5646600

<http://www.globalunichip.com>

FAX: +886-3-5646000

e-mail: [info@globalunichip.com](mailto:info@globalunichip.com)

No. 10, Li-Hsin 6th Rd., Hsinchu Science Park, Hsinchu City 300, Taiwan

## **Deliverables**

- ◆ **Comprehensive document set**
- ◆ **Hard macro**
- ◆ **Synopsys™ synthesis model**
- ◆ **Verilog model**
- ◆ **TLF model**
- ◆ **LEF model**
- ◆ **Test chip**
- ◆ **Evaluation board**

## ***Global Unichip Corp.***

TEL: +886-3-5646600      <http://www.globalunichip.com>  
FAX: +886-3-5646000      e-mail: [info@globalunichip.com](mailto:info@globalunichip.com)  
No. 10, Li-Hsin 6th Rd., Hsinchu Science Park, Hsinchu City 300, Taiwan